

UD Operation

Description of Controls

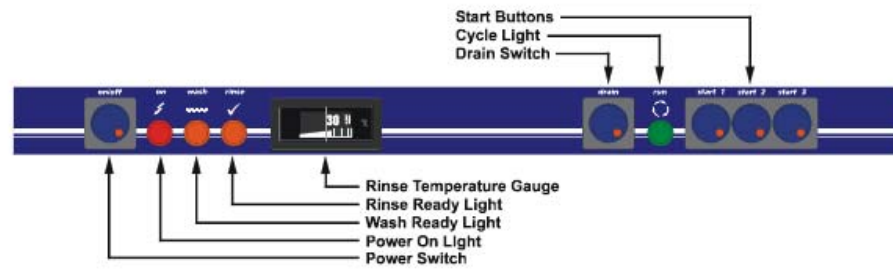

Operating Instructions

START UP

Fit wash pump filter, scrap trays and shut door. Turn wall and machine power switches on. Power light glows red and machine fills automatically. Wash Ready light (water symbol) glows amber when wash tank is ready. Rinse Ready light (tick symbol) glows amber when the machine is up to required temperature and ready to run.

OPERATION

Load rack into machine and shut door. Press Start button (1, 2 or 3) for 1, 2 or 3 minute cycle accordingly. Cycle light glows green while machine operates. When Cycle light goes out, cycle is complete. Remove rack. Close door. NOTE: Machine will not operate unless Ready lights are on.

SHUT DOWN EVERY NIGHT

For models with drain upstand - refer item 2 in drawing to right

Open the door, remove scrap trays and drain upstand. Keep door open and turn Drain switch on. Allow to drain for approximately 2 minutes. Turn Drain and Power switches off. Rinse clean scrap trays and upstand filter and replace.

For models without upstand.

Open the door and turn Drain switch on. Allow to drain for approximately 2 minutes. Turn Drain and Power switches off. Remove scrap trays and wash pump filter, rinse clean and replace.

Performance

PRE-RINSING

Pre-scraping of dishes is required by Food Hygiene Regulations. The best method is to pre-rinse with warm water with a Fisher Pre-rinse Unit - or alternatively by scraping or dunking in water.

Cutlery should be pre-soaked in warm water, preferably containing cutlery pre-soak compound - refer your chemical supplier.

RACKING PROCEDURES

Do not overload racks or cutlery containers, minimise the overlap of crockery. Wash cutlery unsorted, handles down.

Cycle times are short and water consumption per cycle low - so there is no advantage in overloading racks.

CYCLE TIMES

Use the longest cycle - 3 - whenever possible. Water consumption does not increase with longer cycles so only switch to faster cycles when it is necessary.

DETERGENT

Correct type and quantity of detergent is essential for good results. Use good quality chemicals and regularly check containers. Discuss the use of drying agent and cutlery pre soak solution with your chemical supplier.

DRYING

Single tank commercial dishwashers do not have a drying cycle. However, the machines do rinse at high temperatures which promotes fast drying particularly when drying agents are used.

At the end of the cycle promptly remove the rack from the machine - leave the rack on the bench for 2 to 3 minutes before emptying. This time will be reduced with correct use of drying agent (rinse fluid) which reduces water surface tension and allows water to drain quickly from wash ware. For advice on drying agents and injectors refer to your chemical supplier.

Maintenance

DAILY CLEANING

It is essential that the machine is drained and cleaned at the end of each day. Drain the machine as per the shut down instructions. Remove, clean and replace filters. Regularly check the wash and rinse jets and clean if necessary - see below

REGULAR CLEANING - at least once a week

Remove scrap trays 1 and wash pump inlet filter 3, and rinse or brush clean. Remove wash and rinse arms by undoing the central thumbscrews 4. Remove the end cap screws 5 from the wash arms and the end screws 6 from the rinse arms and flush the arms with water. Use a toothpick or paperclip, if necessary, to clear jets.

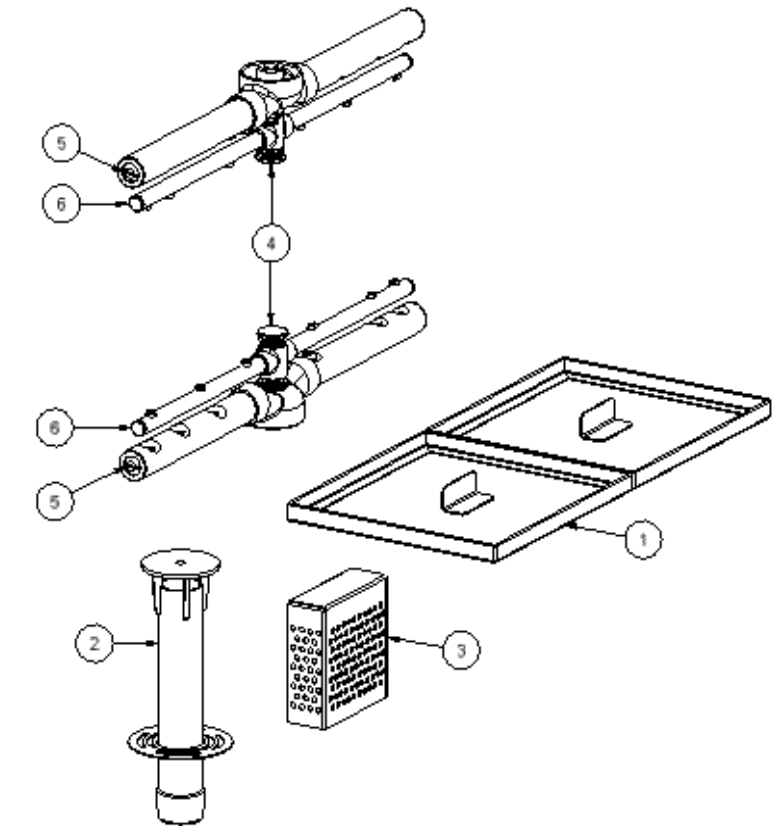

MAINTENANCE

Regular servicing of the dishwasher is essential for high performance, efficient operation and long machine life. Contact us for information on maintenance contracts.