

M2 Operation

Operating Instructions

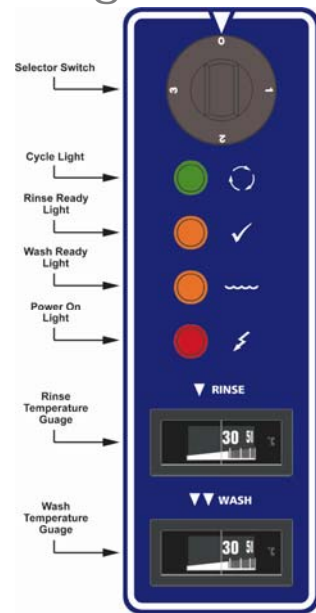

START UP

Fit drain upstand, wash pump inlet filter and scrap trays and shut door. Turn wall and machine power switches on. Power light glows red and machine fills automatically. Wash Ready light (water symbol) glows amber when wash tank is ready. Rinse Ready light (tick symbol) glows amber when the machine is up to required temperature and ready to run.

OPERATION

Select required cycle (1, 2 or 3 minutes). Try cycle 3 initially and switch to faster cycles, only if necessary. Load rack into machine and shut door. GREEN light comes ON and machine starts operating.

Note: Machine will not operate unless AMBER light is ON. Delays may be caused if the temperature of the water supply is low. After removing racks do not shut door as machine will cycle again.

SHUT DOWN -IMPORTANT -EVERY NIGHT

Turn machine and wall switches off. Remove drain upstand to drain wash tank – refer item 2 in drawing to right, Remove filter and rinse clean. Replace drain upstand, filter and scrap trays.

Performance

PRE-RINSING

Pre-scraping of dishes is required by Food Hygiene Regulations. The best method is to pre-rinse with warm water with a Fisher Pre-rinse Unit - or alternatively by scraping or dunking in water.

Cutlery should be pre-soaked in warm water, preferably containing cutlery pre-soak compound - refer your chemical supplier.

RACKING PROCEDURES

Do not overload racks or cutlery containers, minimise the overlap of crockery. Wash cutlery unsorted, handles down

Cycle times are short and water consumption per cycle low - so there is no advantage in overloading racks.

CYCLE TIMES

Use the longest cycle - 3 - whenever possible. Water consumption does not increase with longer cycles so only switch to faster cycles when it is necessary.

DETERGENT

Correct type and quantity of detergent is essential for good results. Use good quality chemicals and regularly check containers. Discuss the use of drying agent and cutlery pre soak solution with your chemical supplier.

DRYING

Single tank commercial dishwashers do not have a drying cycle. However, the machines do rinse at high temperatures which promotes fast drying particularly when drying agents are used.

We recommend prompt removal of the rack from the machine - leave the rack on the bench for 2 to 3 minutes before emptying. This time will be reduced with correct use of drying agent (rinse fluid) which reduces water surface tension and allows water to drain quickly from wash ware. For advice on drying agents and injectors refer to your chemical supplier.

Maintenance

DAILY CLEANING

It is essential that the machine is drained and cleaned at the end of each day. Drain the machine then remove, clean and replace filters as per the operating instructions. Regularly check the wash and rinse jets and clean them if necessary – see regular cleaning.

REGULAR CLEANING

Remove scrap trays 1 and wash pump inlet filter 3 or 4, where fitted, and rinse or brush clean.

Remove wash and rinse arms by undoing the central thumbscrews 5. Remove the end cap screws 6 from the wash arms. If necessary remove end screws from the rinse arms and flush the arms with water and/or use a toothpick or paperclip to clear jets.

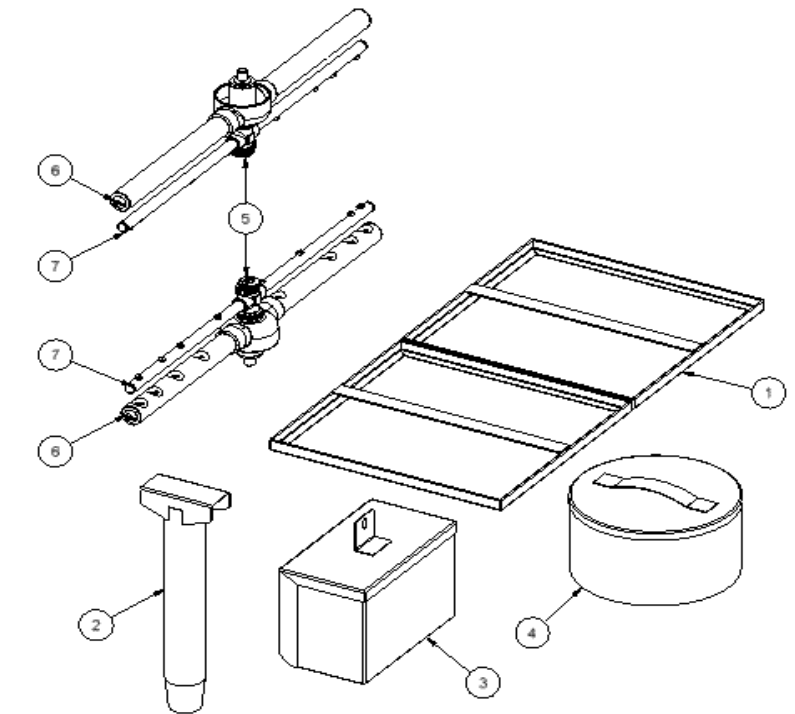

MAINTENANCE

Regular servicing of the dishwasher is essential for high performance, efficient operation and long machine life. Contact us for information on maintenance contracts.