

M2 High Performance Dishwasher

The Starline M2 washes up to 1000 large plates per hour - ideal for most restaurants.

Operator may select 1, 2 or 3 minute cycles to rapidly wash a wide range of soil levels. Powerful rinse booster elements ensure fast recovery between cycles for genuine 55 cycle per hour capacity.

The M2 washes large plates and serving dishes with huge 430mm door clearance height and 500mm racks. Big 750W wash pump recirculates 350 litres per minute for excellent wash performance.

Wash tank width of only 600mm makes the M2 an ideal replacement machine for a wide range of brands and models. 700 bench recommended, 650 sufficient in-line.

Low water consumption of less than 3 litres on all cycles minimises water, waste, power and chemical costs for highly efficient operation.

Effortless operation with light, well balanced door and wrap around handle - auto-starts on door closure.

FASTCLEAN features include: fully enclosed base, one piece door, rounded L shape wash tank, uncluttered internal design, easy-tilt rack slide, double filtration, scrap trays, upper and lower stainless steel wash and rinse arms with removable end plugs, anti-drip door to channel water away from opening, and 220mm legs for excellent access beneath machine.

Standard electrical requirement is 15 amps per phase, three phase, neutral and earth, or 25 amps single phase which may be reduced to 15 amps if required. Qualified installer can choose any of the above options.

Supplied with two dishracks, one cuprack, one cutlery container and one cutlery basket.



Starline products are proudly manufactured in New Zealand by Washtech. Over 25 years Washtech has earned the position of Australasia's leading wash equipment manufacturer by providing robust, reliable machines designed for ease of service and years of effective, efficient operation.



ISO 9001 certified and audited since 1993 - our equipment complies with all local hygiene, electrical and plumbing regulations.



Washtech products are supported nationwide by the STARLINE Service Network to ensure long term access to parts and after sales support and service including preventative maintenance programmes.



In line with policy to continually develop and improve it's products Washtech reserves the right to change specifications and design without notice.

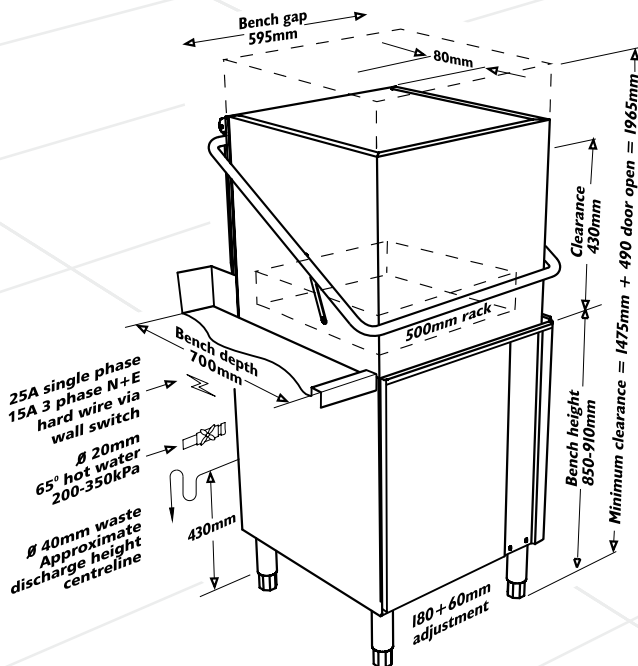

Installation drawing and detail overleaf.

