

# GLV

---

UNDERCOUNTER DISHWASHER



# Operator Manual

# Foreword

---

## User documentation

Please read this manual and keep it in a safe place for future reference.



---

**WARNING**

Before installation and commissioning, you must read the safety instructions and warnings carefully and all the warning labels attached to the equipment.

---



---

**IMPORTANT**

Failure to comply (even partially) with the instructions given in this manual will invalidate the product warranty and relieves the manufacturer of any responsibility.

---



---

**IMPORTANT**

The alteration of machine operation, design or the replacement of parts not approved by the manufacturer may void warranties and approvals.

---

## Warranty Registration

Complete the information below for quick reference.

Model Number \_\_\_\_\_ Serial Number \_\_\_\_\_

Purchased from \_\_\_\_\_ Date of Purchase \_\_\_\_\_

If you require further information regarding authorised service providers or recommended detergent suppliers in your region, or have any other queries, please do not hesitate to contact us.

**IMPORTANT**

TO VALIDATE YOUR WARRANTY, PLEASE COMPLETE AND RETURN THE WARRANTY REGISTRATION CARD WITHIN 30 DAYS FROM THE DAY OF PURCHASE.

---

Information supplied in this manual is copyright. No part of this work may be reproduced or copied in any form or by any means, electronic or mechanical without the express permission of the author / publisher. Document subject to change without prior notice.



Manufactured in  
New Zealand by

**WASHTECH®**

24HR Service 09 829 0923

414 Rosebank Road, Avondale, New Zealand, Tel 09 829 0930, Fax 09 829 0935  
PO Box 90548, Auckland

# Safety Instructions

---



---

## **WARNING**

Equipment contains dangerous voltages and can be hazardous if installed or operated incorrectly. Non-compliance with **Warnings** or failure to follow the instructions contained in this manual can result in loss of life, severe personal injury or serious damage to property.

---

### **Installation**

- ◆ Use qualified, skilled personnel
- ◆ Follow installation instructions
- ◆ Connect to correct voltage and supply current
- ◆ Provide fully accessible Electrical Isolation Switch & water supply valves

### **Training and Supervision**

- ◆ Read and Understand the Operating instructions and train all staff
- ◆ This appliance must not be operated by children or infirm persons
- ◆ Machine panels must only be removed by suitably qualified and trained personnel – internal hazards include live electrics and very hot surfaces
- ◆ This appliance is not intended for use as a stepladder

### **Hot Surfaces**

- ◆ Some surfaces may be hot or very hot

### **Chemicals**

- ◆ Commercial dishwashing detergents are hazardous – handle with care
- ◆ Read and follow the safety information found on the labels of detergent containers and Material Safety Data Sheets
- ◆ Use protective eyewear and clothing if decanting containers

### **Hot Water**

- ◆ Do not put hands in wash water which may be over 60°C and contain hazardous caustic detergent
- ◆ Rinse water can be over 90°C
- ◆ Door safety switches are designed for emergency use only

### **Cleaning**

- ◆ Do not hose down the machine or splash water over the exterior
- ◆ Watch for broken glass etc when cleaning the inside of the machine

### **Service/Repair**

- ◆ Under no circumstances the user should attempt to carry out repairs
  - ◆ All service/repair work must be carried out by qualified personnel only
-

# Installation

---



---

**WARNING**

Installer must be suitably qualified and ensure compliance with all local codes and standards including AS/NZS 3500.1.

---



---

Failure to comply even partially with installation instructions may void the warranty.

---

## Positioning

Unpack machine, check for damage and complete delivery. Install machine on sound waterproof self-draining floor and use adjustable feet to level machine. Adjacent surfaces should be heat resistant and moisture proof, especially benchtop lower surfaces above undercounter machines. Allow room for detergent to one side of machine or in adjacent cupboard. 20litre container requires about 450H x 250W x 350D, but smaller containers are available from many suppliers.

## Water Supply

Hot water temperature	65°C ± 5°C
Connection	20 mm (3/4" BSP) male
Flow rate minimum	20 litres per minute
Consumption per cycle	3 litres approximately
Backflow prevention	Vacuum Breaker fitted standard
Pressure	200-350 KPa = 30-50 Psi

Above this range fit pressure limiter. Don't use small diameter plastic supply lines. FLUSH supply line before connection. Poor quality supply or excessive water hardness may affect performance or damage machine – filtration and/or softening is recommended.

## Waste

Drain pump is fitted – refer installation diagram.

## Power

Machine requires 230V 22A 50Hz single phase, permanent wiring via wall switch to point C on installation diagram. Machine may also be installed on a 15A single phase circuit (with reduced rinse heating). For this requirement remove double adaptor and Red 0.75 wire from rinse over-temperature thermostat and reconnect Red 1.5 mm wire to the over-temp thermostat.

## Detergent

Insert detergent pump inlet hose into container of commercial low foam detergent. Open machine door and switch machine on. Press and hold detergent prime switch behind front cover until chemical flows into machine. Commercial detergents can be hazardous – read instructions and handle with care.

## Rinse Aid

If rinse aid injector is fitted insert injector inlet hose into rinse aid container. Check amount of fluid rising up inside pipe during pulse at start of rinse cycle. Rotate Adjusting screw clockwise to reduce flow and anticlockwise to increase flow.

## Installation Checklist

Complete attached Installation Checklist to ensure machine is installed and running correctly, and operator is familiar with operating procedures.

---

# GLV6 (S) INSTALLATION DIAGRAM

GLV6S 09-04-08 1A

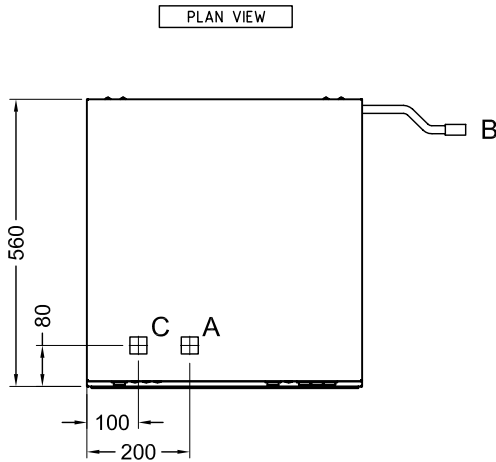
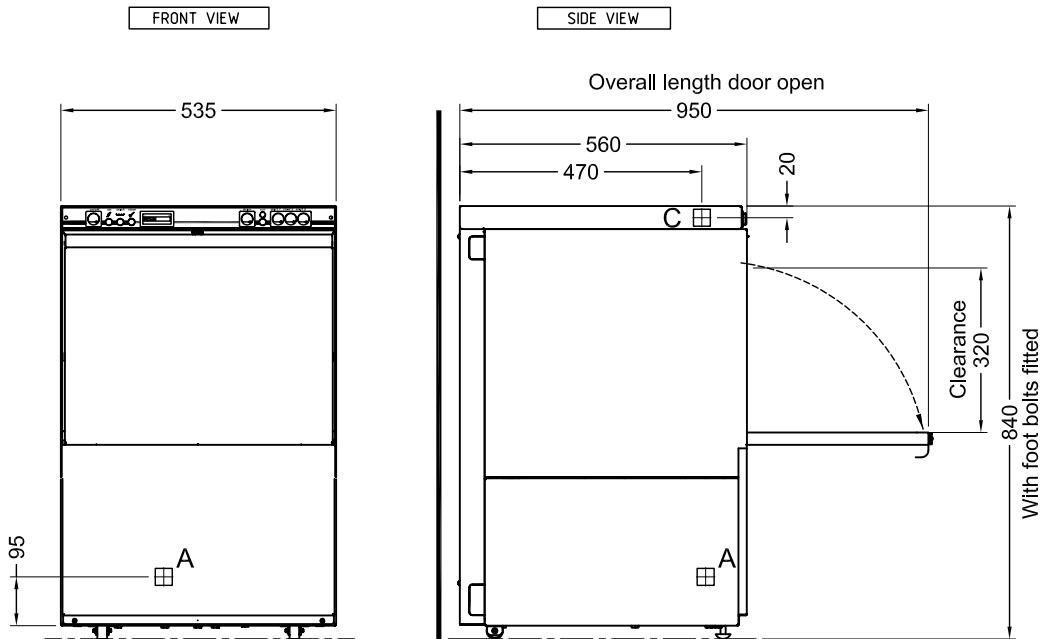

### LEGEND

- A WATER SUPPLY
- B WASTE
- C POWER SUPPLY

All dimensions in millimetres

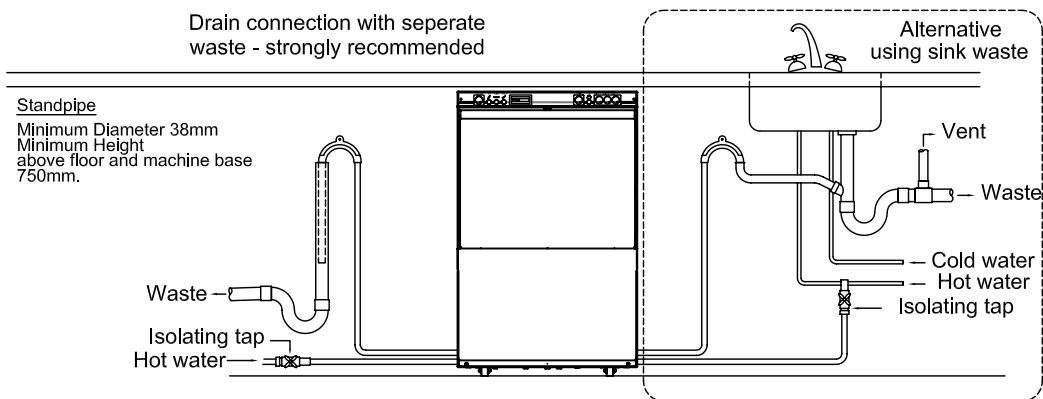



# Operation

---

## Description of Controls

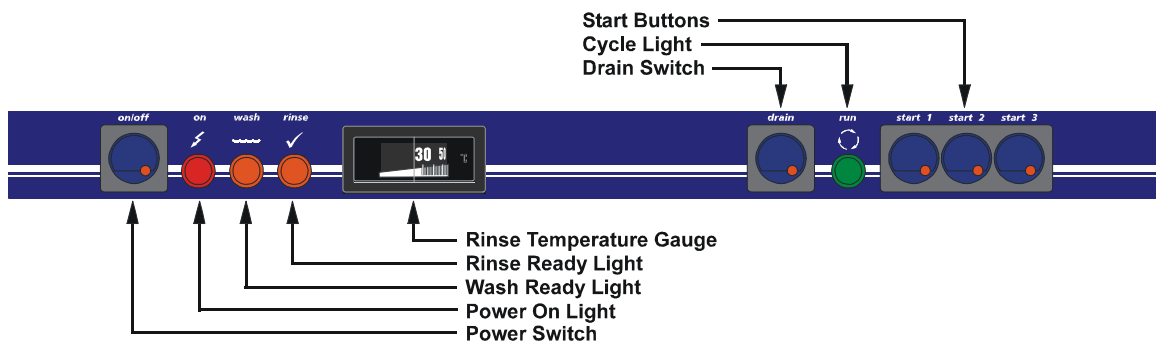

## Operating Instructions

### Start up

Fit drain upstand with filter, scrap trays and shut door.  
Turn wall and machine power switches on.  
Power light glows red and machine fills automatically  
When Wash Ready light and Rinse Ready light glow amber the machine is ready to run and may be started.

### Operation

Load rack into machine and shut door.  
Press Start button (1, 2 or 3) for 1, 2 or 3 minute cycle accordingly.  
Cycle light glows green while machine operates.  
When Cycle light goes out, cycle is complete.  
Remove rack. Close door.

NOTE: Machine will not operate unless Ready lights are on.

### Shut down every night

Open the door, remove scrap trays and drain upstand.  
Keep door open and turn Drain switch on.  
Allow to drain for approximately 2 minutes.  
Turn Drain and Power switches off.  
Rinse clean scrap trays and upstand filter and replace.

---

# Dishwashing Procedures

for best results

Note: these are general instructions to assist in getting the best performance from Starline dishwashers – some comments and / or illustrations may not apply to every unit.

## Installation



Read the Operator Manual. Correct installation, including an adequate supply of water at the correct temperature and pressure is essential for effective operation of your machine. Refer installation instructions for details. Drain hose outlet height is important on some models. Always install on a sound self-draining floor. Water softening is recommended in hard water areas - especially for glasswashing.

## Pre-rinsing



Pre-scraping of dishes is required by hygiene regulations. The best method is to pre-rinse with a pre-rinse spray unit - or alternatively by scraping or dunking in water.



## Cutlery Procedures



Pre-soak cutlery in warm water, preferably containing cutlery pre-soak compound - refer your chemical supplier.

Do not overfill cutlery containers. Cutlery should be loose with handles down. Sort after washing rather than before. Cutlery of only one type nests together and obscures wash water.

## Racking Procedures

Do not overload racks, minimize the overlap of crockery. Cycle times are short and water consumption per cycle low - so there is no advantage in overloading racks.

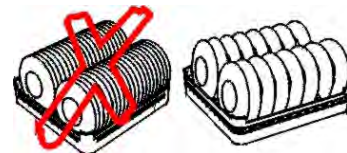

## Cycle Times

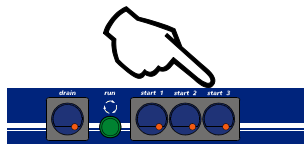

For multi-cycle machine use the longest cycle whenever possible. Note that water consumption does not increase with longer cycles. Only choose shorter, faster cycles when necessary.



## Detergent

Use of correct type and quantity of low foaming commercial grade detergent is essential to the performance of the machine. We strongly recommend that you use a professional dishmachine chemical supplier - and will be pleased to recommend a supplier in your region. Discuss with them the use of cutlery pre-soak solution, detergent and drying agent.



# Dishwashing Procedures

for best results

## Drying



Single tank commercial dishwashers do not have a drying cycle. However, the machines do rinse at high temperatures which promote fast drying particularly when drying agents are used. We recommend prompt removal of the rack from the machine - leave the rack on the bench for 2 to 3 minutes before emptying. This time will be reduced with correct use of drying agent (rinse fluid) which reduces water surface tension and allows water to drain quickly from washware. For advice on drying agents and injectors refer to your chemical supplier.

## Daily Cleaning

It is essential that the machine is drained and cleaned at the end of each day. Drain the machine then remove, clean and replace filters as per the operating instructions. Regularly check the wash and rinse jets and clean them if necessary – see below.

## Regular Cleaning

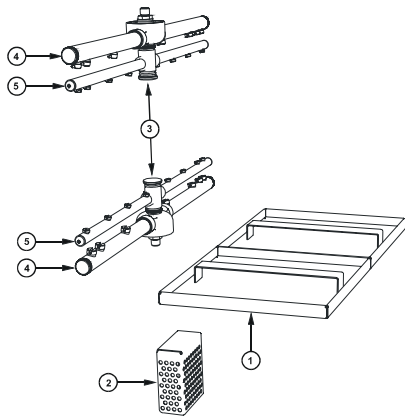

Remove scrap trays<sup>①</sup> and wash pump inlet filter<sup>②</sup>, where fitted, and rinse or brush clean.

Remove wash and rinse arms by undoing the central thumbscrews<sup>③</sup>. If necessary, remove the end cap screws<sup>④</sup> from the wash arms and the end screws<sup>⑤</sup> from the rinse arms and flush the arms with water and/or use a toothpick or paperclip to clear jets.

Note: arms and filters vary with model and may appear different from this illustration e.g. those models with plastic wash arms have removable jets for ease of cleaning.

## Regular Servicing

Regular servicing of the dishwasher is absolutely essential to keep the machine in top working condition and obtain the best performance.

Please contact Washtech or your Authorised Service Provider to organize regular servicing of the dishwasher - discuss a Preventative Maintenance Agreement for optimum performance and long machine life.



Note: these are general instructions to assist in getting the best performance from Starline dishwashers – some comments and / or illustrations may not apply to every unit.

# GLV6/UD6 (S) SCHEMATIC DIAGRAM

030138 9/10/08 3 C

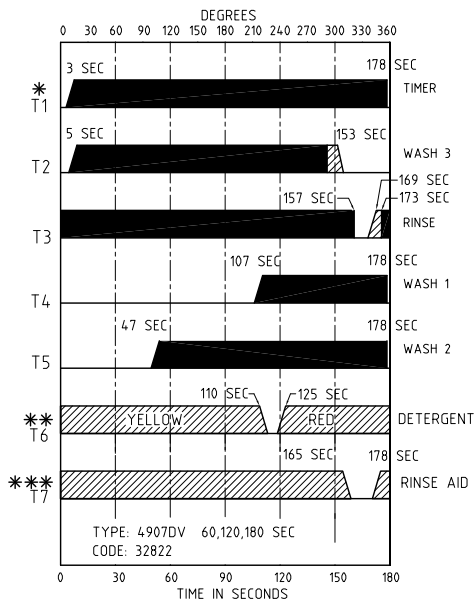
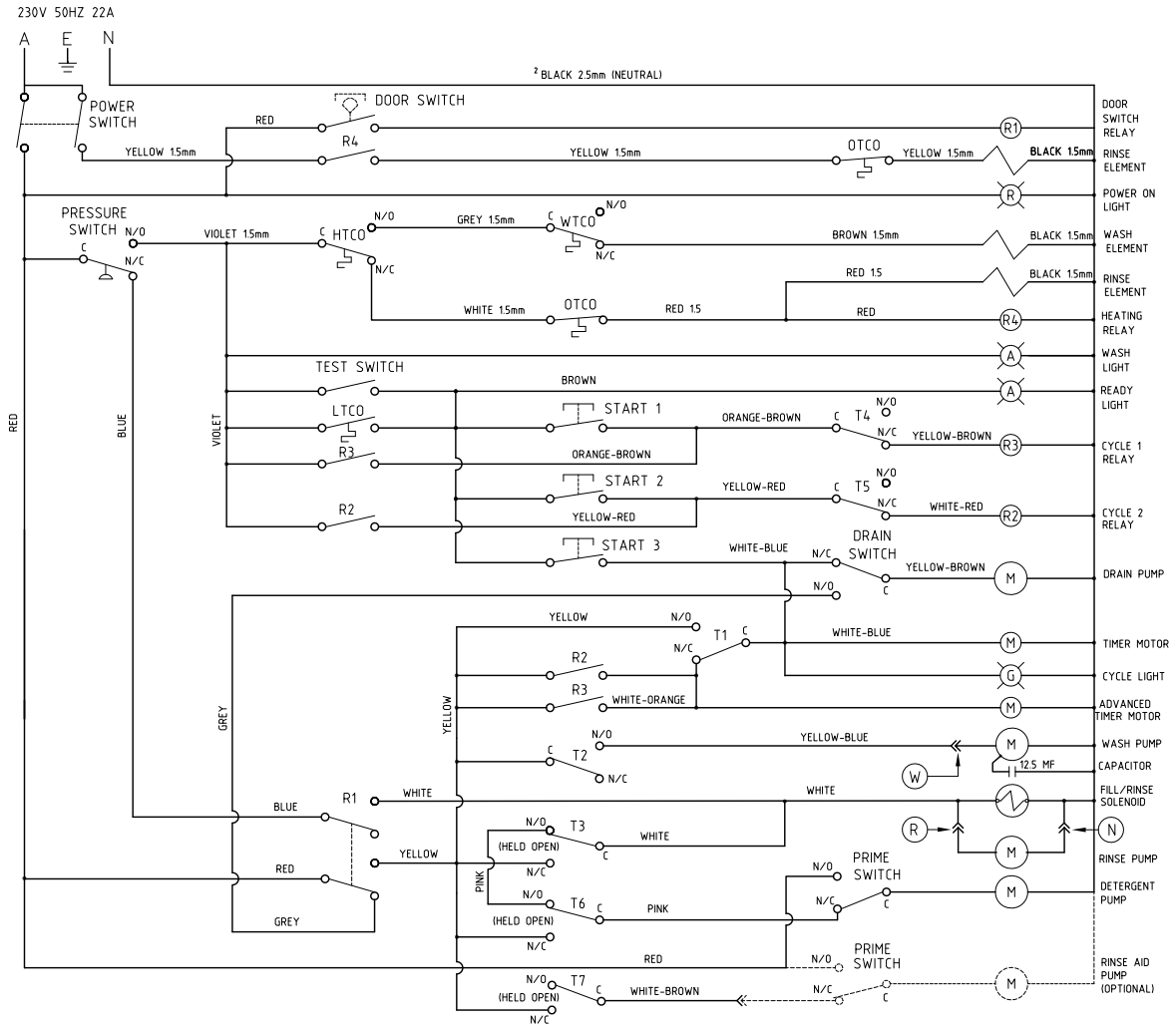

## DETERGENT AND RINSE AID CONNECTION OPTIONS

### Cycle active feed

- Wash Active - refer W - connection to wash pump
- Rinse Active - refer R - connection to fill/rinse solenoid
- Neutral - refer N - connection to fill/rinse solenoid

For rinse aid injection. Washtech part # C620120 is recommended and operates hydraulically.

- \* T1 IS CAM CLOSEST TO 180 SEC. TIMER MOTOR
- \*\* ADJUST T6 AS REQUIRED FOR DETERGENT CONTROL
- \*\*\* ADJUST T7 AS REQUIRED FOR RINSE AID CONTROL

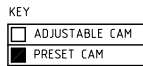

# Warranty

---

**WASHTECH** warrants that new STARLINE products are free from defects in material or workmanship for a period of one year from the date of purchase.

## **EXTENT OF WARRANTY**

- Washtech shall repair or, at its discretion, replace any part of the machine found to be defective.
- The labour for the repairing or the replacement of defective parts shall be provided during normal office hours at no cost to the user.
- Washtech shall not otherwise be liable for any other loss or damage arising out of any person's use or inability to use the machine.
- Washtech shall not be liable for the cost of work done outside normal office hours, and for travel costs outside regional centres.
- Washtech shall not be liable for detergent related issues, including detergent pump adjustment or squeeze tube replacement, drain pump blockages and other related damages.

## **CONDITIONS OF WARRANTY**

**This warranty shall not be binding on Washtech unless the warranty registration card is completed and received by Washtech within 30 days from the date of purchase**

**This warranty shall be void if:**

- The equipment has not been properly installed by an authorised Washtech Service Provider.
- Persons other than Washtech Service Providers have undertaken repairs or attempts at repair.
- The equipment has not been operated and maintained in accordance with the Operator Manual.
- Damage has resulted from shipment, handling, fire, water, accident, abuse, detergent equipment fitted by others or any other event beyond the control of Washtech.

**Any defect must be notified to Washtech or its authorised dealer within 30 days of the discovery of the defect.**

## **IF YOU WISH TO MAKE A WARRANTY CLAIM**

- First check the things you can do for yourself. Refer to the Operator Manual provided to ensure that the machine is correctly installed and that you are familiar with its operation. If a service technician calls and determines that the equipment is not defective you will be charged with the cost of the call-out.
  - If you need service during the warranty period, first contact the dealer from whom you purchased the equipment. The Dealer will arrange service by Washtech or an authorised Starline Service Provider.
  - If you have a problem contacting your dealer or if your dealer is unable to assist, then please contact the Service Department, Washtech, telephone 09 829 0923.
  - When you write or call you will need to provide your name and address, the model and serial number (refer lower front cover) and the date of purchase so that your warranty claim may be validated.
-