

## AL Premium Passthrough Dishwasher

The Starline AL is the fastest and most powerful passthrough dishwasher on the market - washing up to 1400 large plates per hour.

The massive 1.5 kW wash pump recycles wash water at 800 litres per minute through double upper and lower rotating wash arms. With fastest complete cycle time of 40 seconds the AL delivers unrivalled single tank passthrough dishwasher performance and capacity.

Operator selects 40, 60 or 90 second cycles for extremely rapid washing of a wide range of soil levels. Powerful rinse elements ensure rapid recovery between cycles for high capacity.

The AL washes very large plates and trays with 430 door clearance. Big cabinet accepts oversize items such as gastronorm pans - with appropriate optional racks.

Low water consumption of around 3 litres per cycle ensures highly efficient operation - minimising water, waste, power and chemical costs.

Effortless operation with wrap around door handle and light, well balanced door which auto-starts the selected cycle on closure.

Easy to keep clean with FASTCLEAN rounded L shape wash tank, uncluttered internal design, double filtration and removable wash and rinse arm end plugs. Anti-drip door channels water away from the opening and 220mm legs provide excellent access for cleaning beneath machine.

750mm deep benches recommended but 700 is sufficient for in-line installation. Electrical requirement - 15 amps 3 phase, neutral and earth.

Supplied with two dishracks, one cuprack, one cutlery container and one cutlery basket.



Starline products are proudly manufactured in New Zealand by Washtech. Over 25 years Washtech has earned the position of Australasia's leading wash equipment manufacturer by providing robust, reliable machines designed for ease of service and years of effective, efficient operation.



ISO 9001 certified and audited since 1993 - our equipment complies with all local hygiene, electrical and plumbing regulations.



Washtech products are supported nationwide by the STARLINE Service Network to ensure long term access to parts and after sales support and service including preventative maintenance programmes.



In line with policy to continually develop and improve it's products Washtech reserves the right to change specifications and design without notice.

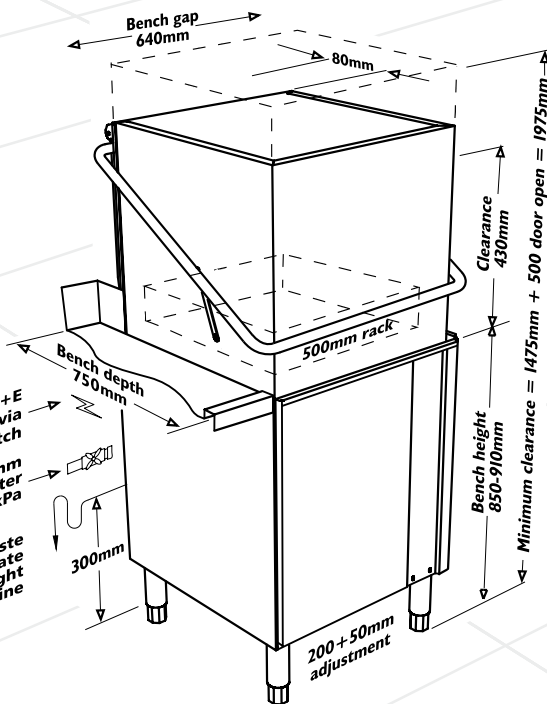

Installation drawing and detail overleaf.

